

Sorane

ZA-12

I N S T R U C T I O N S



Thank you!

Congratulations on the purchase of this tonearm.

We are certain that you will find it a musical
and rewarding addition to your audio system.

It has been prepared by Japanese crafts people
with many decades of combined experience.

Careful installation and adjustment is just as important
as the product that you are installing
without proper alignment and adjustment,
no tonearm can perform its best.

If you have difficulties, please consult your dealer.

s p e c i f i c a t i o n s

| |
|--|
| Whole Length ● 416mm |
| Effective Length (Tonearm pivot - stylus) ● 322mm |
| Practical Length (Tonearm pivot - Spindle) ● 310mm |
| Overhang ● 12mm |
| Offset angle ● 16.5° |
| Horizontal moving sensitivity ● 30mg |
| Vertical moving sensitivity ● < 20mg |
| Vertical Tracking Force (VTF) range ● 0 - 5 g |
| Adaptable Cartridge weight range ● 5 - 60g |
| Height Adjustment (Plinth to arm wand centerline) ● 19 - 35mm |
| Vertical Bearing ● Double bearing pivot Miniature Radial Bearing(840 2 pieces) Pivot miniature bearing (TC-3 2pieces) |
| Horizontal Bearing ● Miniature Radial Bearing 1280 |
| Output plug ● RCA (XLR : Option) |
| Output cable ● Single core shield copper |
| Tonearm Audio Lead wire ● OFC 4N Copper |
| Tonearm Net Weight ● 995gt |

Included Accessories

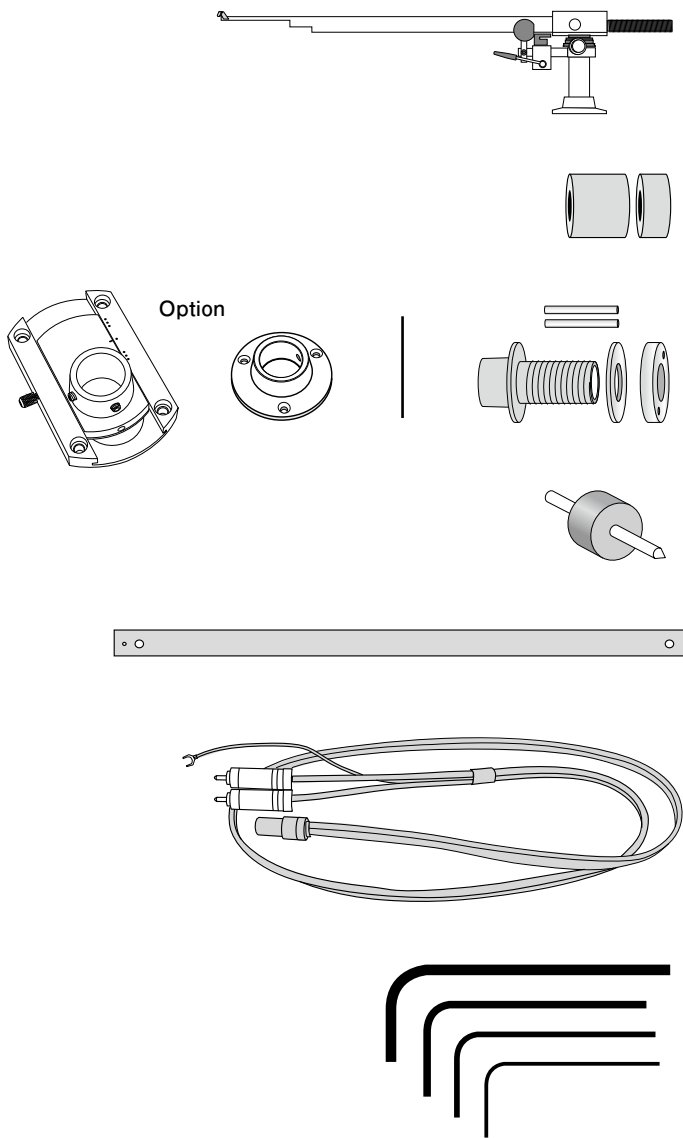

ZA-12

Counter Weirht

Cylinder Type Base

Marking Pin & Bushing

Template

Detachable phono cable

Hex Key

Screws, Washers

SME compatible sliding base,

SSBS,SSBB (Sorane Sliding Base Silver/Black)

Optional parts

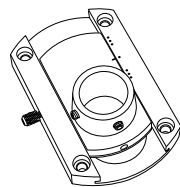

SSBS/B(Sorane Sliding Base with Silver/Black color) are optional parts to replace The SME standard base for customer's convenience. Direction of sliding line of sub-base should go to turn table spindle. Center point length of SSBS in lower-base long hole, from spindle is set by the template.

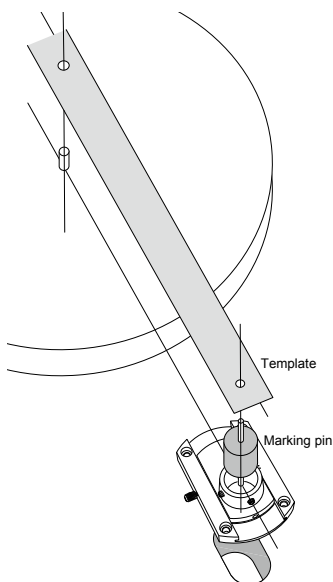

step1 Marking

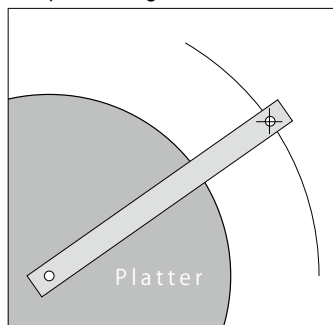

step2 Drilling

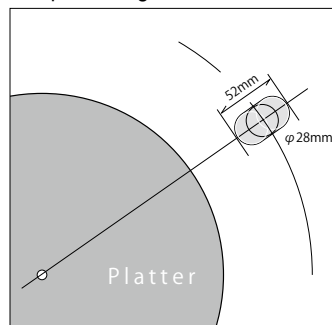

step3 Set up

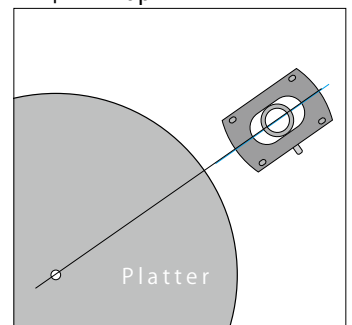

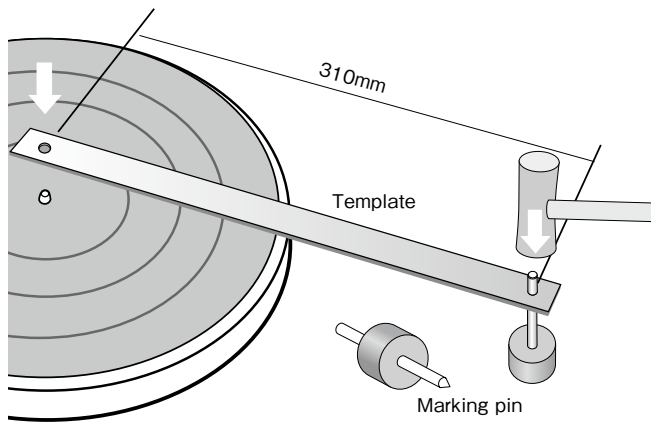

Mount the tonearm collar/base to turntable plinth/armboard

A- Cylinder Type Base (Standard parts)

1-a) Determine where the arm base should be placed by using the arm template supplied.

1-b) Put the large hole of the template over the turntable spindle.

1-c) Use the supplied steel marking pin (as illustrated) and push it through the small hole in the template for the tonearm pivot (on the opposite end of the template from the spindle).

1-d) Using the supplied plastic bushing (round shaped black plastic device with a hole), keep the steel pin perpendicular to the template, also perpendicular to the plinth/armboard, then mark the position of tonearm pivot.

1-e) Having marked the center for this arm pivot, check that if the tone arm is placed in this position, that it will clear the dust cover.

1-f) Following this pivot center marking, drill a hole(31mm- 34mm DIA) in plinth.

1-g) Insert 2 rods in each hole of lower plate of Cylinder Type Base, from bottom side and rotate for tight locking by hand.

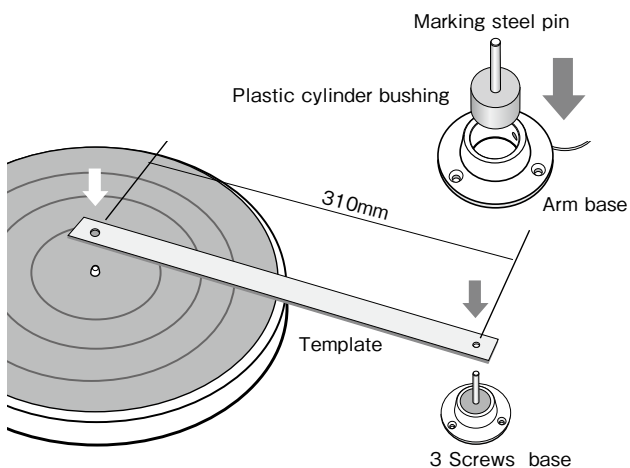
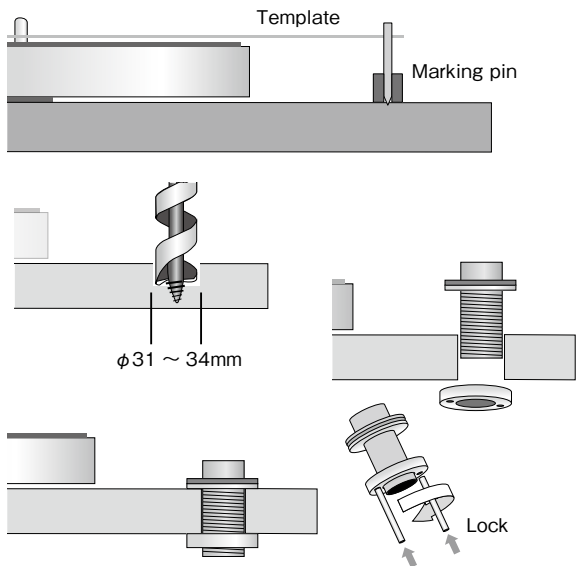

B- 3 Screws Type Base

Optional Parts

1-a) Determine where the arm base should be placed by using the arm template supplied.

1-b) Put the large hole of the template over the turntable spindle.

1-c) Use the supplied steel pin (as illustrated left) and push it through the small hole for the tonearm pivot guide (on the opposite end of the template from the spindle).

1-d) Using the supplied plastic cylinder bushing (round black plastic device with a hole), keep the steel pin perpendicular to the template, also perpendicular to the plinth/armboard, then mark the position of tonearm pivot.

1-e) At the same time, the 3 holes for fixing screws for arm base should also be marked.

1-f) Having marked the center for the arm base/collar, check that if the tone arm is placed in this position, that it will clear the dust cover.

1-g) Drill a 22mm hole and three 3.5mm holes.

* Drilling a hole: 22mm diameter (For tonearm shaft)

* Drilling 3 x 3.5mm diameter (For tonearm base fixing screws)

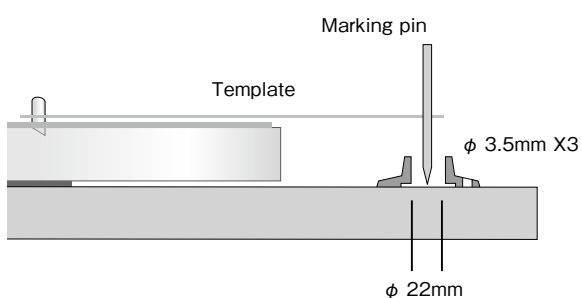

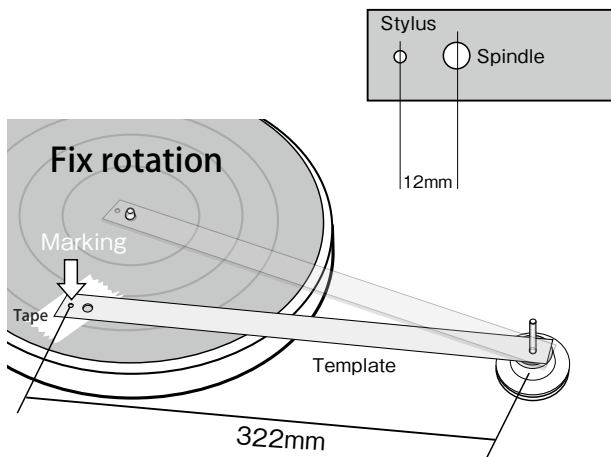

Initial Cartridge overhang point setting

(* The essential operation is to adjust your cartridge position in the slots so that the stylus tip is 322mm from the tonearm pivot.

The Effective Length is 322mm, and this gives the lowest distortion for this tonearm.)

2-a) "In order to set cartridge stylus position, or overhang, precisely, apply removable tape around the expected stylus position on the turntable platter. You must fix/stop the platter from rotating."

2-b) Put the plastic bushing, containing marking pin in the center, in previously fixed Cylinder Type Base hole and put template pivot hole down to marking pin.

2-c) Mark the stylus position on the tape, and leave the tape on the platter.

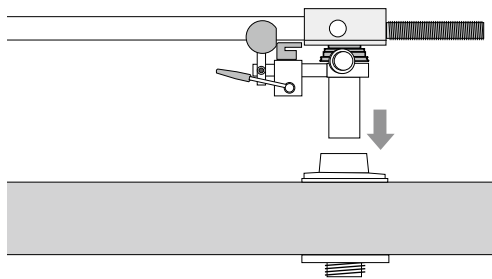

Mount ZA-12 shaft in tonearm base

3-a) Locate the tonearm shaft through the hole in the Cylinder arm base, and then fasten the screw with supplied hex key in half way, to set the cartridge stylus position to match with above 2-c) position on the tape.

(Caution)

"Because the tips of fixing screws in the tonearm base are made of Delrin, a type of durable plastic, be sure not to over-tighten these screws."

Delrin plastic
Do not lock tightly

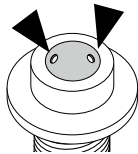

Carefully mount cartridge to tonearm

4-a) At this point, you might decide to mount your phono cartridge if your cartridge has a stylus guard. If your cartridge does not have a stylus guard, it might be advisable to install the cartridge after the tonearm is mounted on the armboard/plinth. This is up to the user, and Sorane bears no responsibility for accidental cartridge damage.

4-b) Put the cartridge in half way to the arm with the hardware supplied with the cartridge.

4-c) Adjust the cartridge so it is halfway down the slots. This will allow you to "rough in" the tracking force before fine-tuning the overhang of the cartridge.

4-d) VERY carefully attach the tonearm wires to the cartridge with needle nose pliers. Since these wires are NOT user-replaceable, we urge you to go slowly. When sliding the "tag" over the "pin", be sure to firmly grip the "tag" where your needle-nose pliers are pressed against the metal "wings" of the "tags".

4-e) If the cartridge "tag" doesn't want to slip over the cartridge output "pin", it might be necessary to carefully open the "tag" with something like a metal pick, or toothpick, just enough at the end to allow the "tag" to start sliding over the "pin".

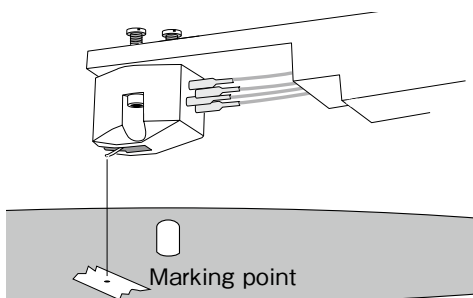

4-f) "After mounting the cartridge on the tonearm, slide the cartridge body until the stylus tip touches the spot/dot marked on the tape applied to the platter, referring to section 2-c above."

4-g) Confirming precise length of 322mm for Effective Length (Cartridge stylus to the arm pivot), now tighten cartridge in the slot.

4-h) Once the tonearm is installed in the arm base, and cartridge in the slot, it might be necessary to adjust the cueing platform. The cueing platform can be adjusted by using the supplied hex key. The correct position of the platform is when the arm is parallel to the surface of the plinth/armboard, when the arm is in the rest position.

Cartridge tracking force adjustment

5-a) It is necessary to use a cartridge tracking force gauge of some kind. The VTF (tracking force) cannot be set accurately without the use of a measurement device that shows force in grams, one that is repeatable, and is relatively accurate (better than .05 grams, at least).

5-b) With the cartridge permanently fitted in the correct position, adjust the counterweight (Consisting of 2 weights, to make firm position of counterweight on the weight shaft, by tightening 2 pieces with each other) so that the arm is floating with the stylus approximately 3-5mm above a vinyl record. It should be remembered that any time you adjust the overhang of a phono cartridge, the tracking force will change. So, it will be necessary to readjust the tracking force if the overhang is adjusted. Tracking force adjustment should be made with the anti-skating knob to zero.

5-c) Slowly rotate the counterweight so that it moves forward (towards the tonearm pivot). It will be necessary to make multiple adjustments. Add force gradually. Do not add too much, then remove force, as you could damage your phono cartridge. Be patient and add it slowly for the benefit of your cartridge.

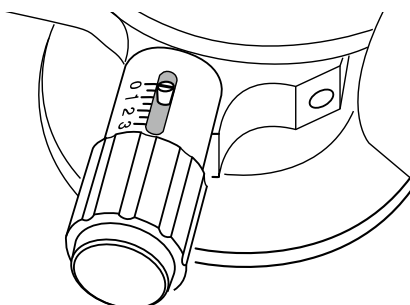
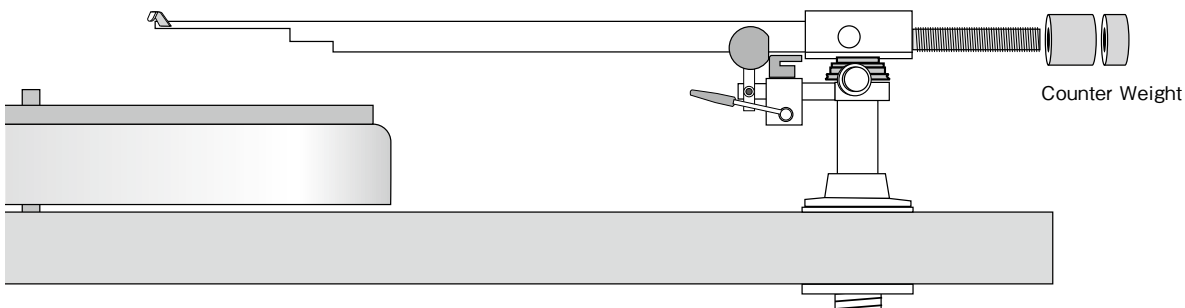

Anti-Skating (bias) adjustment

6-a) Set the bias adjustment knob to the same number as the required tracking force. Sometimes this is best accomplished through trial and error since the stylus profile will affect skating forces.